

# High Spatial Resolution Scintillation Detector based on the H8500 Photomultiplier

R. Engels, *Member IEEE*, U. Clemens, G Kemmerling, and J. Schelten

**Abstract**—The Flat-Panel photomultiplier (Hamamatsu H8500) can be utilized as a high resolution area detector for thermal neutrons and high energy gamma rays. This detector type is useful for special neutron scattering experiments and for the PET applied to small animals. In various test measurements this will be demonstrated by coupling suitable scintillators (NaI, BGO, LiI single crystals, <sup>6</sup>Li-glass, and LiGd-Borate) to the photocathode and by feeding the 64 output signals of the photomultiplier (PM) into an active resistor network. The four output signals from the network are transferred to the pulse processing board (UniDAQ) where the event position address is calculated and where the event storage is done by memory increment.

## I. INTRODUCTION

Nowadays diffraction and scattering experiments with thermal neutrons are commonly performed with large area detectors which cover large solid angles at a distance of 1m to 20m from the sample. In this case the required spatial resolution is moderate and in the order of 5mm.

However, the situation changes if the sample size is limited and only 1mm<sup>3</sup> or less sample volume is available. In such cases the adequate detector is an area detector with less than 1mm spatial resolution and with a sensitive area of 50 mm x 50 mm [1],[2].

There are other applications for such high resolution area detectors:

In neutron diffraction experiments with small single crystals it is not always sufficient to determine only the integrated intensities of a Bragg peak. Often a detailed peak profile analysis is required in order to do an advanced background separation and to reveal and evaluate double peaks.

In reflection and refraction experiments where a narrow beam hits the sample surface at glancing angles a multi detector with high spatial resolution is mandatory. Simultaneously the angular intensity of the reflected and scattered beam is recorded which contains information of the topology and composition of surface layers.

For alignment purposes such a small high resolution detector is useful provided the detector is portable and is equipped with a life display.

By changing the scintillator the detector becomes a high resolution area detector for gamma rays. This detector is valuable in specialized cases of Positron Emission Tomography (PET). If the PET method is applied to small animals, e.g. rats and mice, a high spatial resolution is needed while a small detector size is tolerable [3].

It is the purpose of this paper to describe a new scintillation detector system based on the H-8500 (Flat Panel) Hamamatsu photomultiplier (PM) showed in Fig.1. This PM has 8x8 anode pads of 5.6mm x 5.6mm size and 6mm pitch. The common cathode has a non-uniformity of  $\pm 50\%$ .



Fig. 1 Picture of the H-8500 (Flat-Panel) Hamamatsu Photmultiplier

On the cathode side a light disperser glass plate of 4.5 mm thickness is optically coupled. The scintillator is attached with an 1mm air gap to the light disperser.

The 64 output signals of the PM are fed into an active resistor network which will be described in the next section. Four output signals are transferred from this network to the

---

Manuscript received October 30, 2003.

R. Engels is at Zentrallabor für Elektronik in the Forschungszentrum Juelich GmbH, 52425 Juelich, Germany (telephone +49 (0) 2461 612878, email: [r.engels@fz-juelich.de](mailto:r.engels@fz-juelich.de)).

U. Clemens is at Zentrallabor für Elektronik in the Forschungszentrum Juelich GmbH, 52425 Juelich, Germany (telephone +49 (0) 2461 615499, email: [u.clemens@fz-juelich.de](mailto:u.clemens@fz-juelich.de)).

G. Kemmerling is at Zentrallabor für Elektronik in the Forschungszentrum Juelich GmbH, 52425 Juelich, Germany (telephone +49 (0) 2461 613186, email: [g.kemmerling@fz-juelich.de](mailto:g.kemmerling@fz-juelich.de)).

J. Schelten is at Institut für Schichten und Grenzflächen in the Forschungszentrum Juelich GmbH, 52425 Juelich, Germany (telephone +49 (0) 2461 613287, email: [j.schelten@fz-juelich.de](mailto:j.schelten@fz-juelich.de)).

pulse processing board (UniDAQ) where the x and y coordinates of the absorption event is calculated in order to address a memory location in a 32Mbyte RAM which then is incremented [5].

For experiments at spallation neutron sources a time coordinate must be added. Such a Time-Of-Flight (TOF) mode must be implemented because future neutron experiments will be done predominantly at pulsed spallation sources.

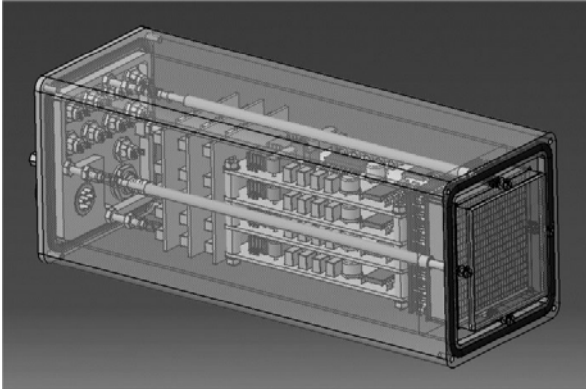

Fig. 2 Three dimensional view of the detector assembly showing scintillator, disperser, PM, network and housing

The following properties should be achievable with this neutron detector:

Even with the well known  ${}^6\text{Li}$  glass scintillator a spatial resolution of less than 0.5mm can be expected. Due to the linear pulse distribution the detector will respond linearly in the position-to-channel relation [4]. The detector can be expected to be stable, because all 64 anode pads are within one PM housing. The detector is fairly insensitive to high energy gammas because of the option to discriminate by pulse height in a position-dependent way.

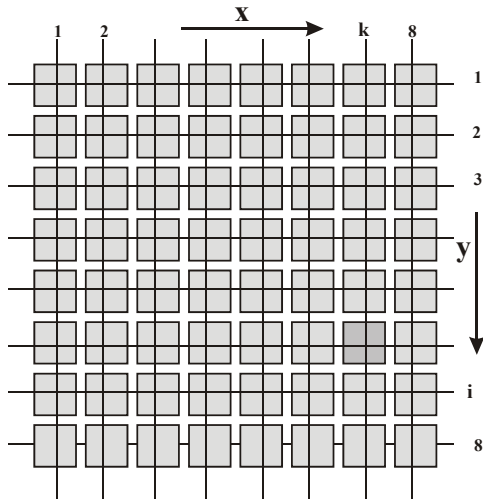

Fig. 3 Anode pad array of the PM with the position coordinates x, y and the indexing i, k.

With a gamma sensitive scintillator, e.g. BGO and gammas from a  $\text{Tc}^{99\text{m}}$  source of 141keV energy a spatial resolution of less than 1mm is expected. All other properties are expected to be as in the neutron case.

## II. ACTIVE RESISTOR NETWORK

The purpose of the active resistor network is to distribute the 64 anode signals finally on to four SUM amplifiers and 50 Ohm line drivers. The output signal  $X_1, X_2$  and  $Y_1, Y_2$  are transferred to the digital pulse processing board (UniDAQ) where the ratios

$$q_x = \frac{X_2}{X_1 + X_2} \quad (3)$$

and

$$q_y = \frac{Y_2}{Y_1 + Y_2} \quad (4)$$

are calculated. They represent the x and y coordinates of the position where the neutron absorption event occurred. Position and index coordinates are shown in Fig.3

The 64 anode signals are treated in the network in such a way that signal  $U^{i,k}$  of the PM located in line i and column k contribute

$$\text{with } \frac{1}{2} U^{i,k} \frac{i}{N+1} \quad \text{to } Y2,$$

$$\text{with } \frac{1}{2} U^{i,k} \left(1 - \frac{i}{N+1}\right) \quad \text{to } Y1,$$

$$\text{with } \frac{1}{2} U^{i,k} \frac{k}{N+1} \quad \text{to } X2, \text{ and}$$

$$\text{with } \frac{1}{2} U^{i,k} \left(1 - \frac{k}{N+1}\right) \quad \text{to } X1.$$

Note, that the contribution to the Y signals depend solely on the line number and the contribution to the X signals depends solely on the column numbers and that the contributions are linear functions of the numbers.

This bilinear signal processing requires 64 charge amplifiers, two times eight SUM amplifiers which form eight line and eight column SUM signals, and another four SUM amplifiers which perform two weighted SUMs of line and column signals.

The various steps of signal processing are described in Fig 4 and Fig.5 .

Since all PMs are supplied with the same high tension each anode pad must have its own charge sensitive amplifier for gain adjusting purposes. The output of each amplifier is given by

$$U^{i,k} = \frac{1}{C} V_{SE}^{i,k} \eta_e^{i,k} M^{i,k} \quad (5)$$

where  $M^{i,k}$  is the number of photons at the cathode of the PM anode pad  $i,k$  for a neutron event. These photons are converted into photo electrons with the quantum efficiency  $\eta_e^{i,k}$ . These photo electrons are multiplied by the gain  $V_{SE}^{i,k}$  and fed into the charge amplifiers with the integration capacitance  $C_{int}$ . The result of this is the output pulse  $U^{i,k}$  of equation (5).

Fig. 3 shows the current distribution into line and column SUM amplifiers via the two resistor branches  $R^{i,k}_v + R$ . All 64  $R^{i,k}_v$  resistors will be adjustable in such a way that the current distribution of all 64 anode pads are the same irrespectively of

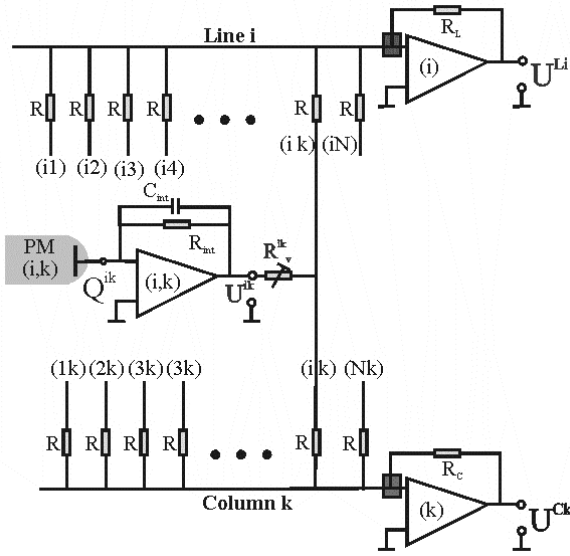

Fig. 4 Current distributions into line and column SUM amplifier.

the gain values  $V_{SE}^{i,k}$ . From test measurements we know that the gain fluctuates within a range of 1:3. It is assumed that this adjustment of 64 resistors must be done once for ever. If not, the manipulation by hand with potentiometers must be changed into a computerized operation. The output of the line SUM amplifier (i) called  $U^{Li}$  in Fig. 3 is given by

$$U^{Li} = \sum_{k=1}^N U^{i,k} \frac{2}{2R_v^{i,k} + R} R_L \quad (6)$$

and the output of column SUM amplifier (k) named  $U^{Ck}$  in the same figure is given by

$$U^{Ck} = \sum_{i=1}^N U^{i,k} \frac{2}{2R_v^{i,k} + R} R_C \quad (7)$$

By inserting (5) in (6) and (7) we obtain the adjustment condition (8)

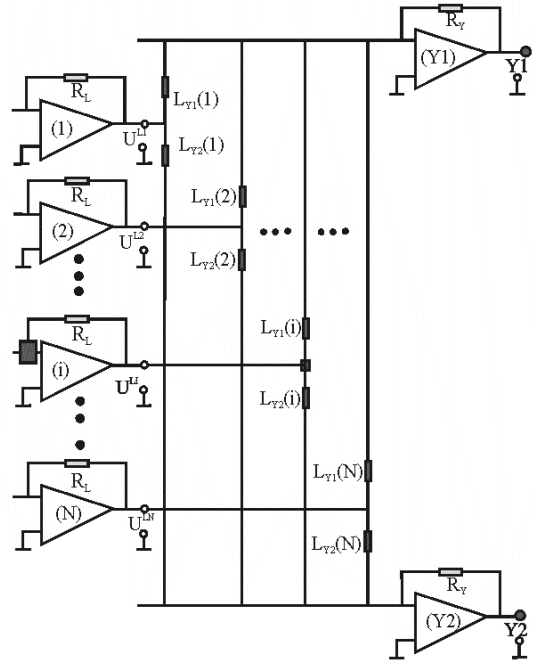

Fig. 5 Weighted distribution of line sum signals onto the SUM amplifiers Y1 and Y2.

$$\frac{V_{SE}^{i,k}}{R_v^{i,k} + R/2} = const \quad (8)$$

The currents generated by the signals  $U_{i,k}$  are flowing into the virtual grounds of the line and column SUM amplifiers. This implies that there is no cross talk possible in the network.

In the final step the line and column signals are distributed on to two Y and X amplifiers, respectively. In Fig. 4 the distribution is shown for the line signals. The weighted signal splitting into two currents feeding the SUM amplifiers Y1 and Y2 is determined by the conductance's of resistor pairs with values

$$L_{Y1}(i) = L \frac{i}{N+1} \quad (8)$$

$$L_{Y2}(i) = L \left( 1 - \frac{i}{N+1} \right) \quad (9)$$

In Table 1 a possible set of such resistors leading to a linear signal splitting is shown for the Y and X branches. The absolute values are still changeable for instance by multiplying all values with the same factor. For our detector which is under construction the following resistor values are chosen.

$$\begin{aligned}
R &= 47\text{k}\Omega \\
C_{\text{int}} &= 100\text{pF} \\
R_{\text{V}}^{\text{ik}} &= 0 - 50\text{k}\Omega \\
R_{\text{C}}=R_{\text{L}} &= 200\text{k}\Omega \\
R_{\text{X}} = R_{\text{Y}} &= 25\text{k}\Omega \\
L &= 0.075 \text{ 1/k}\Omega
\end{aligned}$$

Assuming that at the cathode side 400 electrons will be generated at the position opposite to the anode pad  $i,k$  and assuming the PM gain is  $10^6$  we expect a pulse of height  $U^{\text{ik}} = 640\text{mV}$ .

TABLE 1  
A SET OF RESISTORS IN  $\text{k}\Omega$  FOR A LINEAR CURRENT DISTRIBUTION CALCULATED WITH  $L = 0.075 \text{ 1/k}\Omega$  ACCORDING TO (8) AND(9)

Sum Amplifier			Sum Amplifier		
i	Y1	Y2	k	X1	X2
1	120	15	1	120	15
2	60	17.14	2	60	17.14
3	40	20	3	40	20
4	30	24	4	30	24
5	24	30	5	24	30
6	20	40	6	20	40
7	17.14	60	7	17.14	60
8	15	120	8	15	120

This pulse generates at line SUM amplifier  $i$  and column SUM amplifier  $k$  an output voltage of  $U^{\text{Li}} = U^{\text{Ck}} = 2.5\text{V}$  assuming a medium  $R_{\text{V}}^{\text{ik}}=25\text{k}\Omega$ . This leads to the sum values

$$\begin{aligned}
U_{\text{Y1}} + U_{\text{Y2}} &= U^{\text{Li}} L R_{\text{Y}} = 4.8\text{V} \\
U_{\text{X1}} + U_{\text{X2}} &= U^{\text{Ck}} L R_{\text{X}} = 4.8\text{V}
\end{aligned}$$

### III. PRESENT STATUS

The detector assembly has been designed and the components are being machined in the mechanical workshop.

The printed circuit boards for the active resistor network are fabricated and under test.

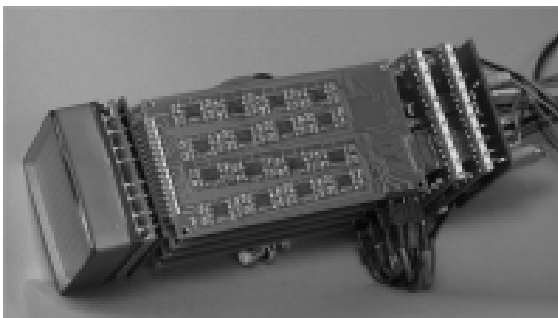

Fig. 6 Detector head with PMT and printed circuit boards under test

The photomultiplier was electronically tested with a collimated light source scanned across the photocathode.

The digital signal processing board is ready for use.

Preliminary neutron measurements can be done in the electronic lab with a weak neutron source.

The detector development and real neutron and gamma experiments need much more time than originality participated.

Thus interesting results can not be described presently.

### IV. REFERENCES

- [1] International Workshop on Thermal Neutron Detectors for the American Spallation Neutron Source, *Brookhaven National Laboratory*, September 25 (1998)
- [2] European Workshop on Thermal Neutron Detectors for the European Spallation Source, *TU in Delft, Netherlands*, October 27-28 (1998)
- [3] S. Weber, A. Terstegge, R. Engels, H. Herzog, R. Reinartz, P. Reinhart, F. Rongen, H. W. Mueller-Gaertner, and H. Halling, "The KFA TierPET: Performance characteristics and measurements," *Nuclear Science Symposium & Medical Imaging Conference, IEEE Conference Record*, p. 1117, 1996.
- [4] R. Kurz, R. Reinartz, S. Widdau, J. Schelten and A. Scholz, "Two-dimensional Neutron Detector based on a position-sensitive Photomultiplier", *Nucl. Instrum. Meth. A273 (1988) 273-282*.
- [5] Engels R., Clemens U., Rongen H., Busmann N., Kemmerling G., Reinartz R. and Schelten\* J, "A flexible data acquisition board for Nuclear Detectors", *IEEE Trans. Nucl. Sci.*, vol. 49, no 3, pp 923-925, June 2002